



PYA 2019 Profile



Automotive Group



Plastic & Rubber Injection

Mexico City

- Annual sales: \$15 M USD
- Employees: 150



Plastic & Rubber Injection

Irapuato, Guanajuato

- Annual sales: \$18 M USD
- Employees: 207



Plastic & Metal stamping

Mexico City

- Annual sales: \$1.5 M USD
- Employees: 36



Plastic injection

Mexico City

- Annual sales: \$22 M USD
- Employees: 190



"WE ARE COMMITTED TO SATISFYING OUR CLIENT'S CURRENT AND FUTURE NEEDS, ALWAYS IMPROVING THE QUALITY OF OUR PRODUCTS, FOLLOWING A MINDSET OF ZERO DEFECTS AND ENVIRONMENTAL AWARENESS."



**New Facility
Solar Powered**

History

Who is PYA?

“ PYA, headquartered in Mexico City and Irapuato is a Mexican Tier 1 manufacturer for the Automotive Industry that has over 38 Years of experience”



1981 – Company established as a rubber manufacturer

1982 – Tier 2 OEM * Hella

1983 – Silicone swimming goggles developed for Speedo

1984 – Tier 1 OEM for Nissan

1990 – Grommets for Valeo

1992 – Masks for MSA

1995 – Plastic division is founded

1995 – Plastic division is founded

1996 – Robert bosch braking components

1997 – Vel-Con incorporates PYA's CVJ boots for GM

1998 – Plant relocation to meet expanding needs

2000 – Design department created

2001 – Laboratory expansion MTS , weatherometer

2002 – ISO9002 / QS9000

2003 – Tyco Electronics electric box developed

2004 – ISO TS16949

2005 – PVC water strips Sekurit Saint Gobain

2006 – PYA USA created

2007 – PVC water strip developed for Vitro

2011 – Kinugawa Is a new Customer for PYA



“TO BECOME A GREEN LEADER
IN PRODUCT INNOVATION AND
NEW MATERIAL SUPPLY IN
NORTH AMERICA ACROSS OUR
BUSINESS UNITS.”

Products

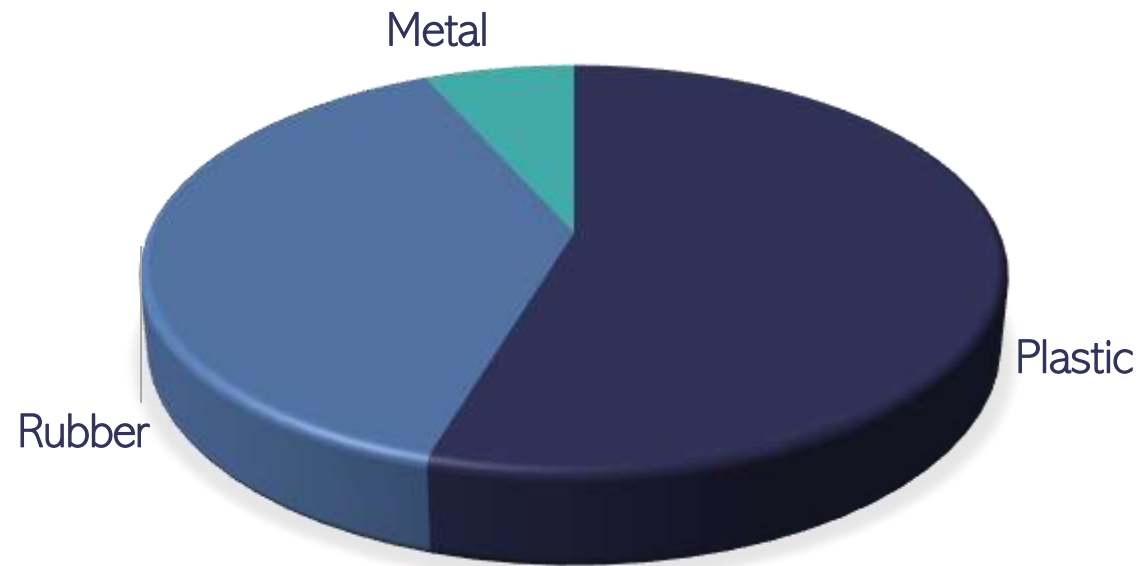

Plastic VS Rubber



- 2012 – New Facility opens in Irapuato , Molten (Mazda)
- 2013 – Injection Capacity increase, New expansión
- 2013 – CTPS founded metal stamping
- 2014 – SOP for Mazda New Hella line for A7 VW
- 2015 – Kasai and BOS SOP model Audi Q5
- 2016 – New Rubber Plant and plant expansión finished
- 2017 – Tesla , BMW , Volvo Mercedes
- 2018 – PYA Detroit Sales office
- 2019 – New Plant in Bajio
- 2019 – CTPS & PYA Fusion

Products

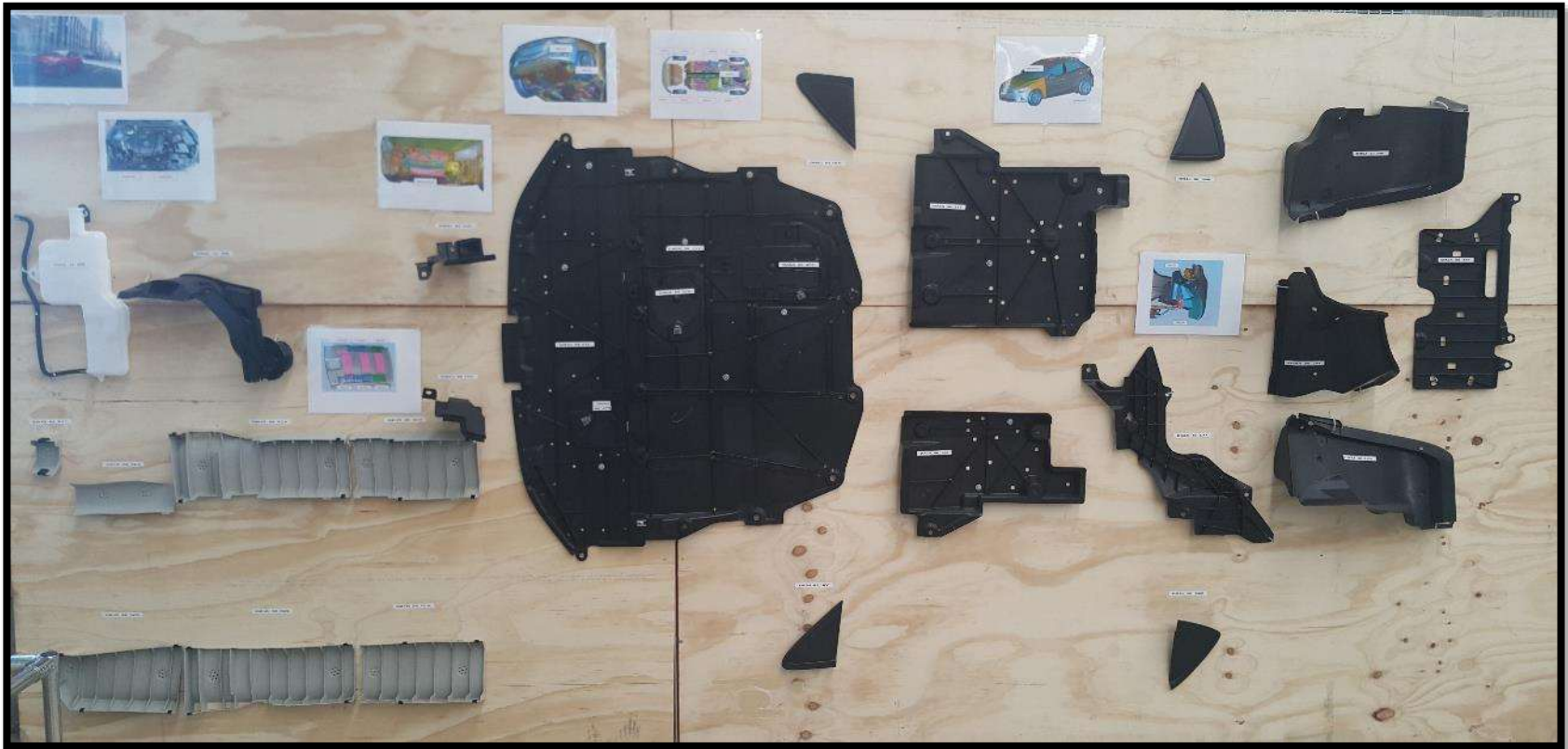

○ Products



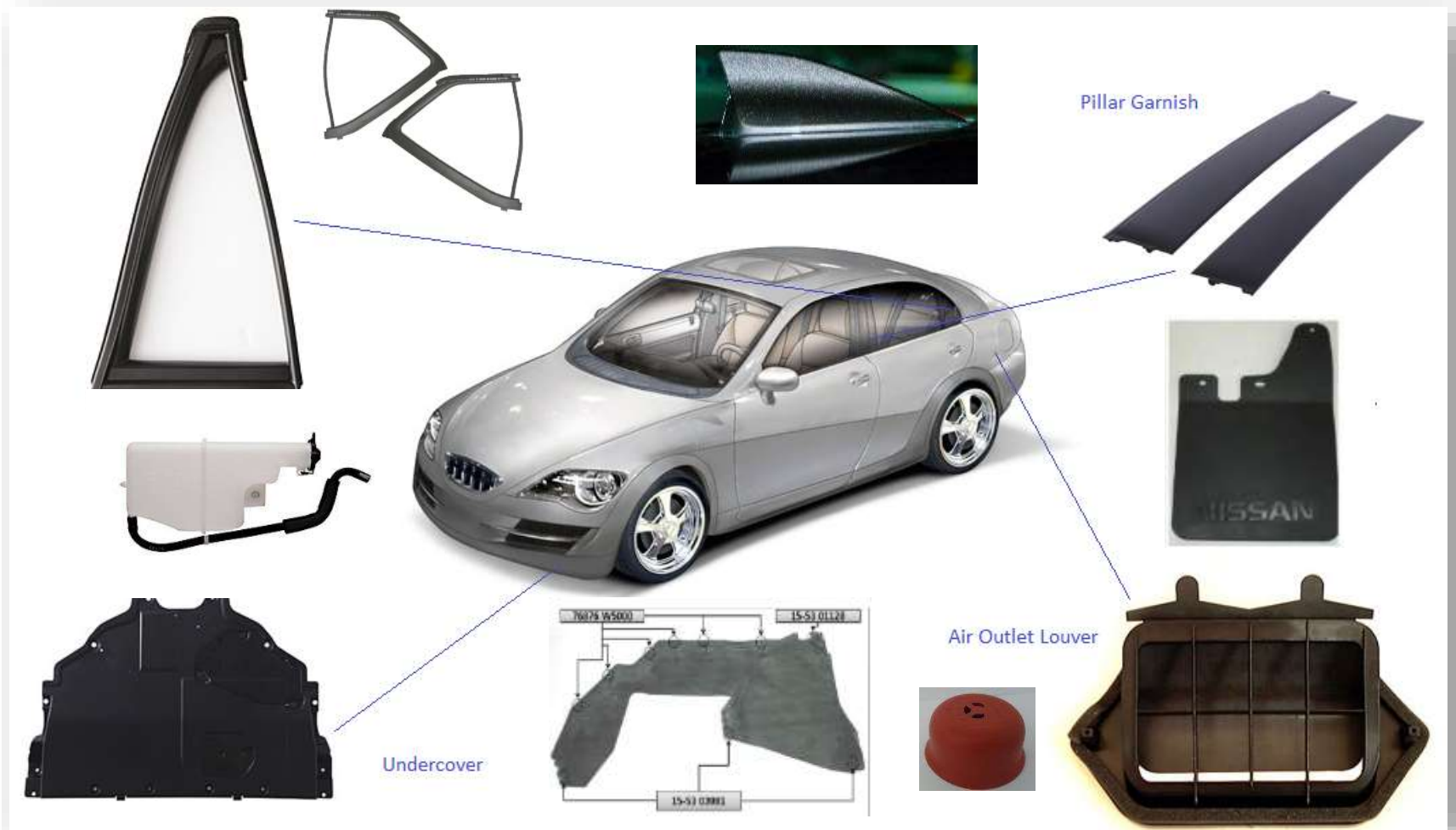



Pi



Arm Rest

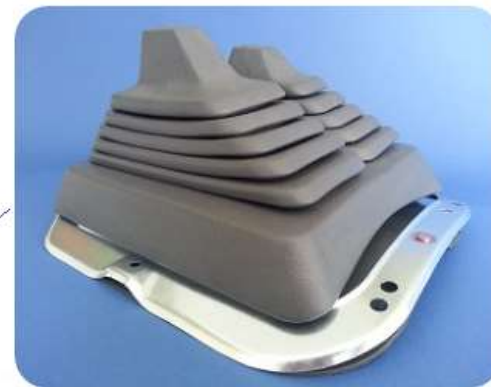
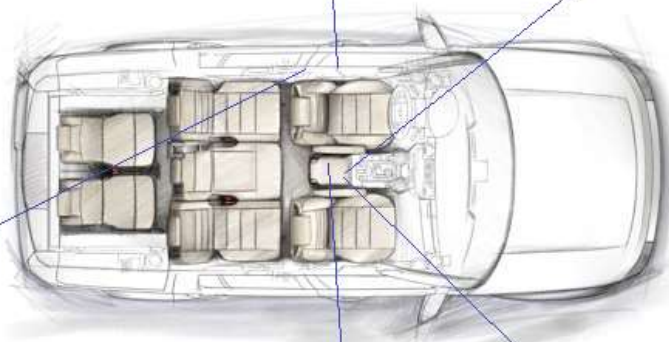

Boot



Boot & Insul Trans Hole



Arm Rest



Suspension & AntiVibration



Steering Hole cover



Protector cover

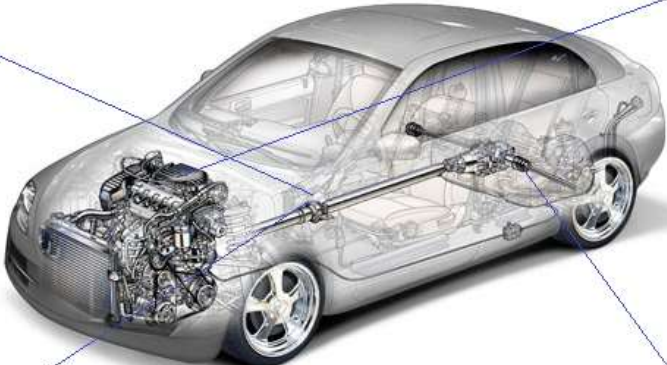

Homo Kinetic Boots





Rubber Grommet



Exhaust Mount

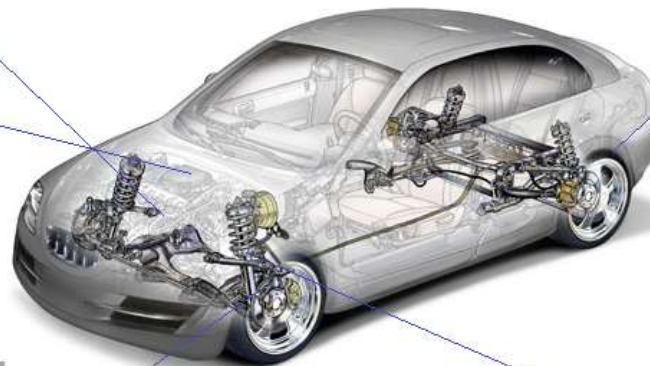

Mounting Seat Rubber



Extruders



Rubber >Bumpers



Rubber Bumpers And Plugs



Bound Bumper





2K and Paint

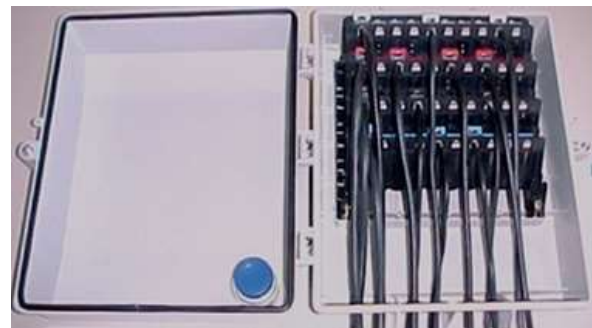





CTPS
PRECISION STEEL AND PLASTIC

Models





PYA automotive



PYA Desing and Test office CDMX

Partnership with Tata Engineering and Design in NNA and Asia

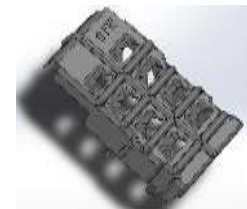
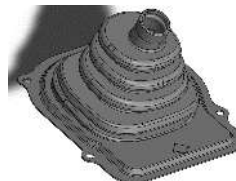
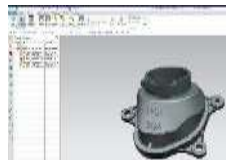
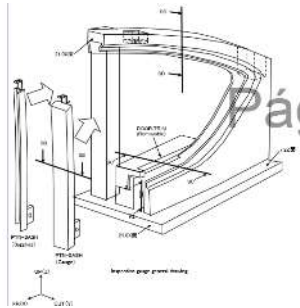

CLIENTS



KINUGAWA



MITSUMI



MSA



faurecia



FICOSA

Machines

50T - 1800T



ARBURG

rep

JSW The Japan Steel Works, LTD.

KraussMaffei

Awards



NISSAN

NNA-SQD

4/23/2019

MONTHLY QUALITY REPORT FOR NORTH AMERICAN REGIONAL SUPPLIERS- MARCH 2019 (Plant Level)

Supplier: 1792000-POLIMEROS Y AMIANTOS SA DE CV CUAUTITLAN IZCALLI
Global Code: 2N46

Region: NNA
Address: ALESSANDRO VOLTA #34, PARQUE INDUSTRIAL CUAMATLA CUAUTITLAN, EM

Year to Date Status (As of Reporting Month)

Score	Status
99.1 / 100	L1 

Performance Indicator			
Rank Level	L1	L2	L3
Points	90-100	80-89	60-79
Status Indicator			
	Meets Expectations	Marginal	Improvement Required

Quality Index Breakdown (12 Month Rolling)

Index	Total Index Points	Type	Category Points		Performance		
			Performance	Target Achieve	Actual	Target	TA Ratio
SP-3MIS	34.1 / 35	3MIS Warranty	22.9	11.2	1.4 IPM	4.0 IPM	0.3
Ranking	35.0 / 35	Disruptions	23.0	12.0	0.0	2.0	0.0
PPM	10.0 / 10	Delivery Quality	7.0	3.0	0.0 PPM	1.1 PPM	0.0
Q-Speed	10.0 / 10	Design	3.5	3.0	0.0 Days	87.0 Days	0.0
		Manufacturing	3.5		0.0 Days	23.0 Days	0.0
Response	10.0 / 10	Plant Rating	10.0		10.0	10.0	
R/S Occur	(0.0)	Recall / Service	0.0		0.0	0.0	
P/M Occur	(0.0)	Part Modification	0.0		0.0	0.0	
Production Prep	(0.0)	Production Prep	0.0		0.0	0.0	
ePPM	(0.0)	Export Part Quality	0.0				
Change Mgmt	(0.0)	FSCR / PCR	0.0				

Zero Defects	Excellence,	Master of Quality
1992 to 1994, 1998, 2000, 2002, 2007, 2008, 2010	1996	1997 to 2002

Testing



CMM
MTS
Simulated weather tests
Weatherometer
Reometer
Optical comparator
3D modeling
Color Test
Gloss Test



Assembly



For further information please contact:

Germán Carrasco

Commercial Director, PYA

germanj@pyaglobal.com

+52 (1) 55 2271 2112



www.pyaautomotive.com